

Heterojunction Bipolar Transistor Technology (InGaP HBT)

Broadband High Linearity Amplifier

The MMG3002NT1 is a General Purpose Amplifier that is internally input and output matched. It is designed for a broad range of Class A, small-signal, high linearity, general purpose applications. It is suitable for applications with frequencies from 40 to 3600 MHz such as Cellular, PCS, BWA, WLL, PHS, CATV, VHF, UHF, UMTS and general small-signal RF.

Features

- Frequency: 40–3600 MHz
- P1dB: 21 dBm
- Power Gain: 20 dB
- Third Order Output Intercept Point: 37.5 dBm
- Single Voltage Supply
- Internally Matched to 50 Ohms
- Low Cost SOT–89 Surface Mount Package
- Pb–Free Leads
- In Tape and Reel. T1 Suffix = 1000 Units per 12 mm, 7 inch Reel.

MMG3002NT1

**40–3600 MHz, 20 dB
21 dBm
InGaP HBT**

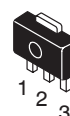

**CASE 1514–01, STYLE 1
SOT–89
PLASTIC**

Table 1. Typical Performance (1)

Characteristic	Symbol	900 MHz	2140 MHz	3500 MHz	Unit
Power Gain (S21)	G_p	20	18	14.5	dB
Input Return Loss (S11)	IRL	–16	–26	–16	dB
Output Return Loss (S22)	ORL	–12	–8	–11	dB
Power Output @ 1dB Compression	P1db	21	21	18.5	dBm
Third Order Output Intercept Point	IP3	37.5	36	32	dBm

1. $V_{CC} = 5.2$ Vdc, $T_C = 25^\circ\text{C}$, 50 ohm system

Table 2. Maximum Ratings

Rating	Symbol	Value	Unit
Supply Voltage (2)	V_{CC}	7	V
Supply Current (2)	I_{CC}	400	mA
RF Input Power	P_{in}	12	dBm
Storage Temperature Range	T_{stg}	–65 to +150	$^\circ\text{C}$
Junction Temperature (3)	T_J	150	$^\circ\text{C}$

2. Voltage and current applied to device.

3. For reliable operation, the junction temperature should not exceed 150°C .

Table 3. Thermal Characteristics ($V_{CC} = 5.2$ Vdc, $I_{CC} = 110$ mA, $T_C = 25^\circ\text{C}$)

Characteristic	Symbol	Value (4)	Unit
Thermal Resistance, Junction to Case	$R_{\theta JC}$	46.5	$^\circ\text{C}/\text{W}$

4. Refer to AN1955/D, *Thermal Measurement Methodology of RF Power Amplifiers*. Go to <http://www.freescale.com/rf>.
Select Documentation/Application Notes – AN1955.

Table 4. Electrical Characteristics ($V_{CC} = 5.2$ Vdc, 900 MHz, $T_C = 25^\circ\text{C}$, 50 ohm system, in Freescale Application Circuit)

Characteristic	Symbol	Min	Typ	Max	Unit
Power Gain (S21)	G_p	19.3	20	—	dB
Input Return Loss (S11)	IRL	—	-16	—	dB
Output Return Loss (S22)	ORL	—	-12	—	dB
Power Output @ 1dB Compression	P1dB	—	21	—	dBm
Third Order Output Intercept Point	IP3	—	37.5	—	dBm
Noise Figure	NF	—	4.2	—	dB
Supply Current ⁽¹⁾	I_{CC}	95	110	125	mA
Supply Voltage ⁽¹⁾	V_{CC}	—	5.2	—	V

1. For reliable operation, the junction temperature should not exceed 150°C .

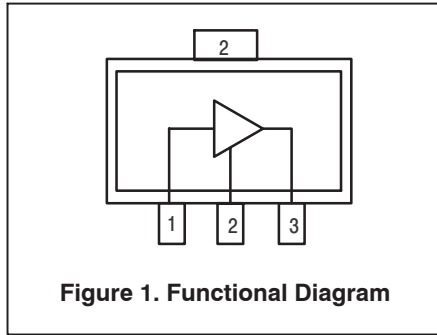

Table 5. Functional Pin Description

Pin Number	Pin Function
1	RF _{in}
2	Ground
3	RF _{out} /DC Supply

Table 6. ESD Protection Characteristics

Test Conditions/Test Methodology	Class
Human Body Model (per JESD 22-A114)	1B (Minimum)
Machine Model (per EIA/JESD 22-A115)	A (Minimum)
Charge Device Model (per JESD 22-C101)	IV (Minimum)

Table 7. Moisture Sensitivity Level

Test Methodology	Rating	Package Peak Temperature	Unit
Per JESD 22-A113, IPC/JEDEC J-STD-020	1	260	°C

50 OHM TYPICAL CHARACTERISTICS

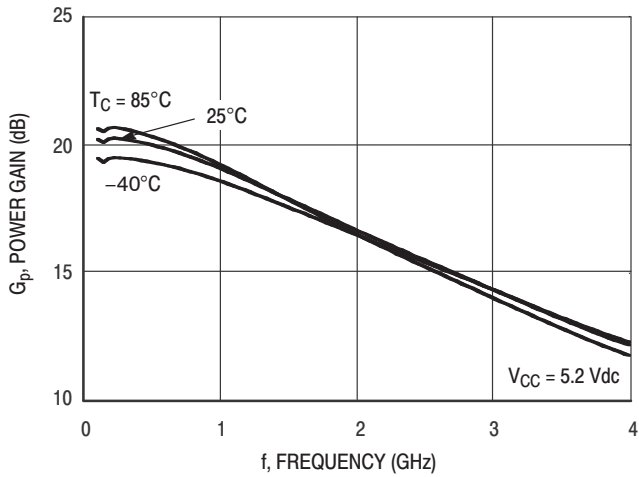

Figure 2. Unmatched Power Gain (S21) versus Frequency

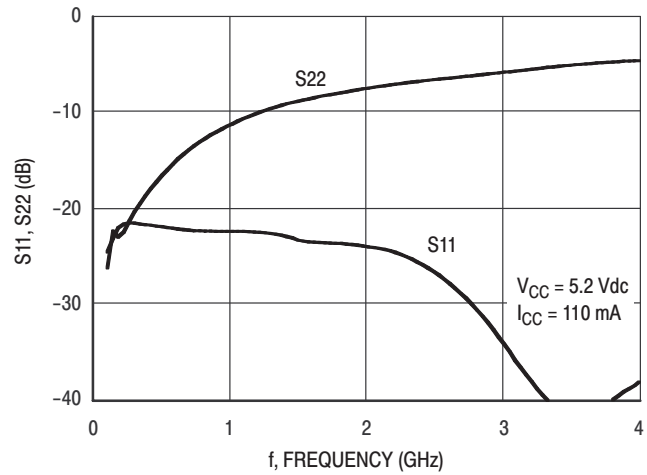

Figure 3. Unmatched Input/Output Return Loss versus Frequency

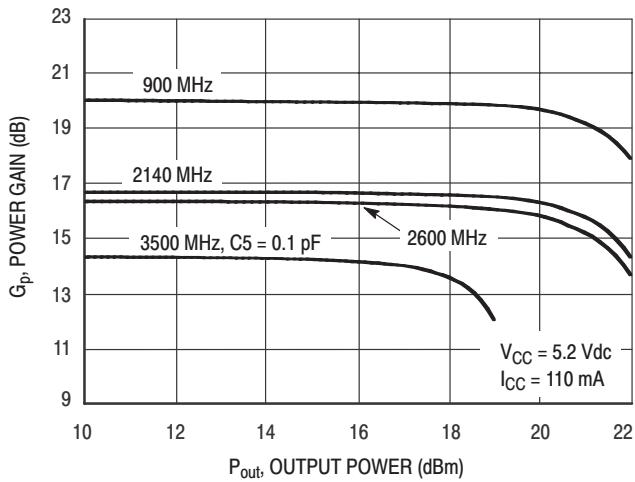

Figure 4. Power Gain versus Output Power

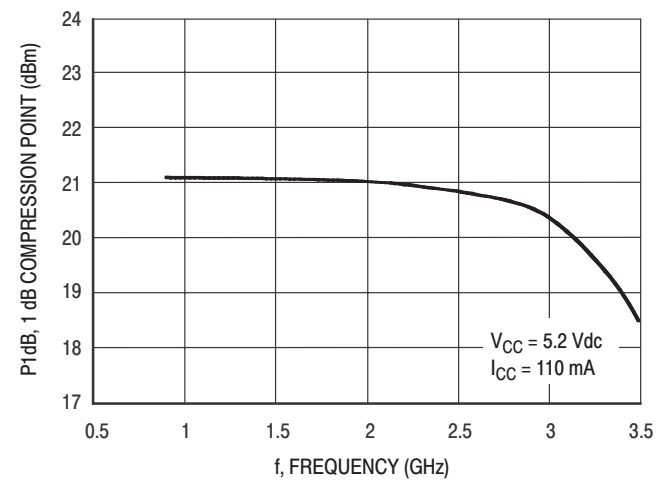

Figure 5. P1dB versus Frequency

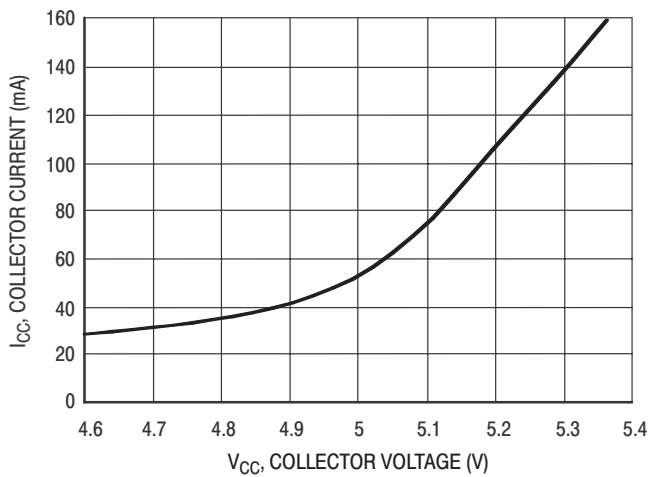

Figure 6. Collector Current versus Collector Voltage

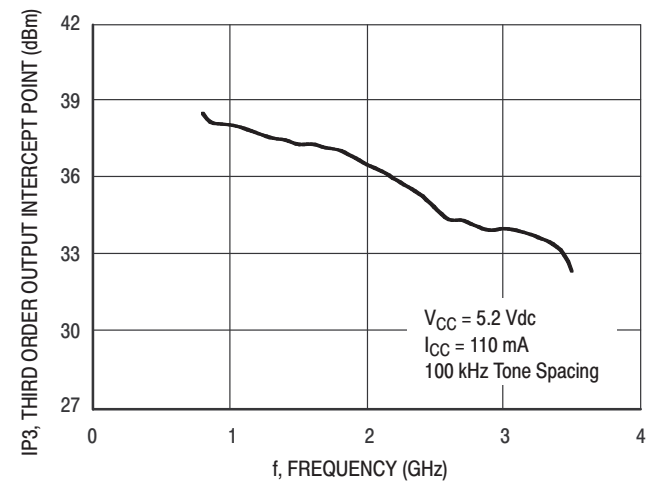

Figure 7. Third Order Output Intercept Point versus Frequency

50 OHM TYPICAL CHARACTERISTICS

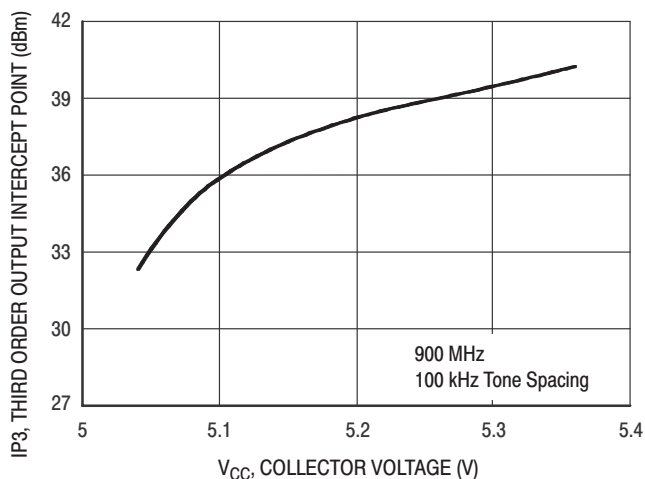

Figure 8. Third Order Output Intercept Point versus Collector Voltage

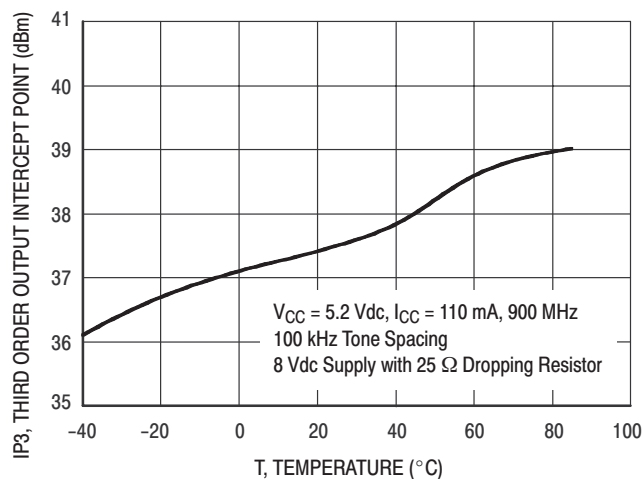

Figure 9. Third Order Output Intercept Point versus Case Temperature

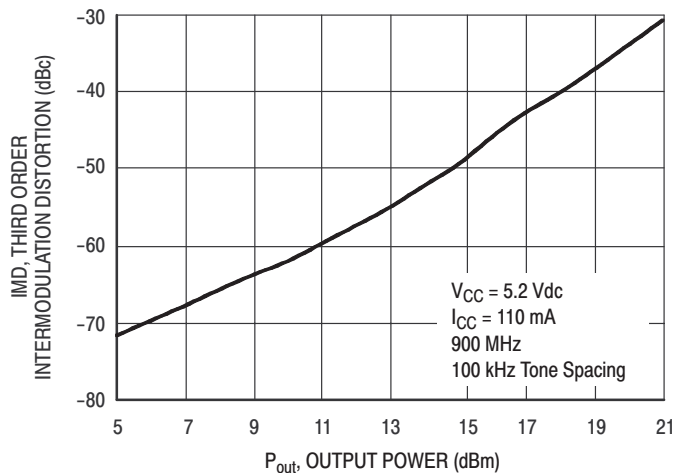

Figure 10. Third Order Intermodulation versus Output Power

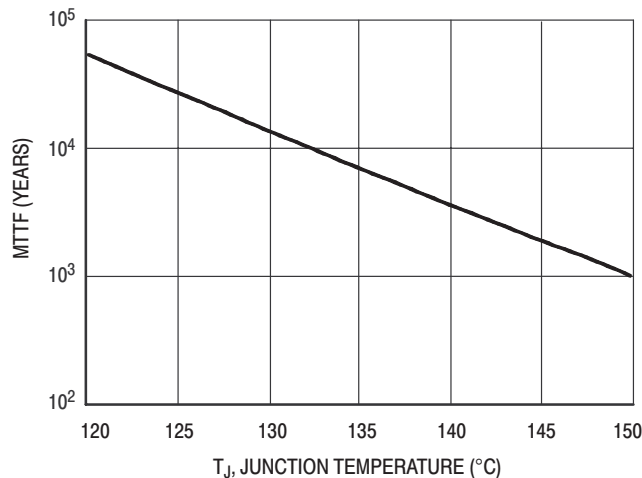

Figure 11. MTTF versus Junction Temperature
NOTE: The MTTF is calculated with $V_{CC} = 5.2$ Vdc, $I_{CC} = 110$ mA

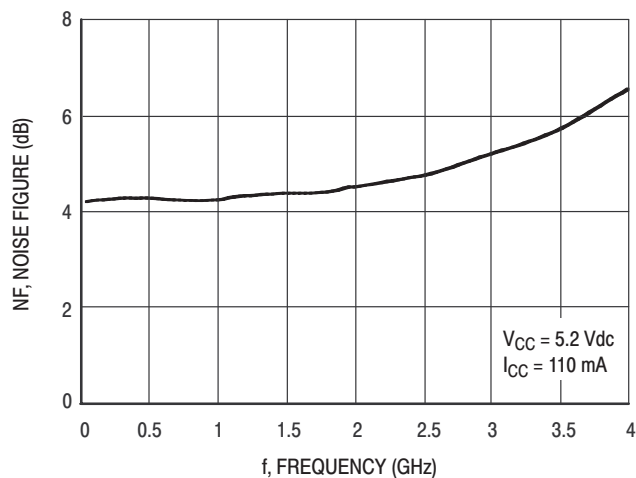

Figure 12. Noise Figure versus Frequency

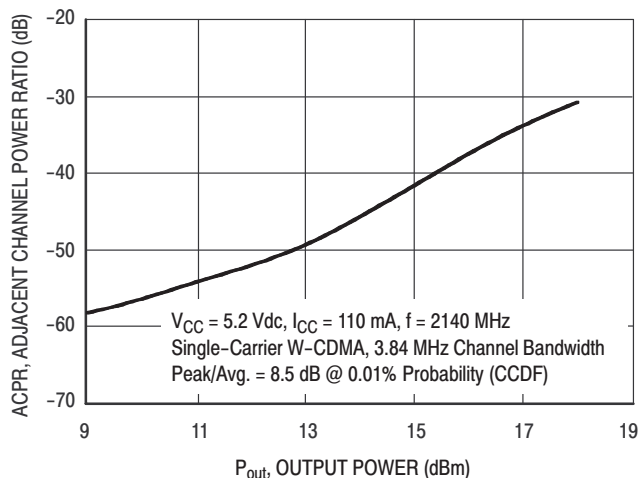

Figure 13. Single-Carrier W-CDMA Adjacent Channel Power Ratio versus Output Power

MMG3002NT1

50 OHM APPLICATION CIRCUIT: 40–800 MHz

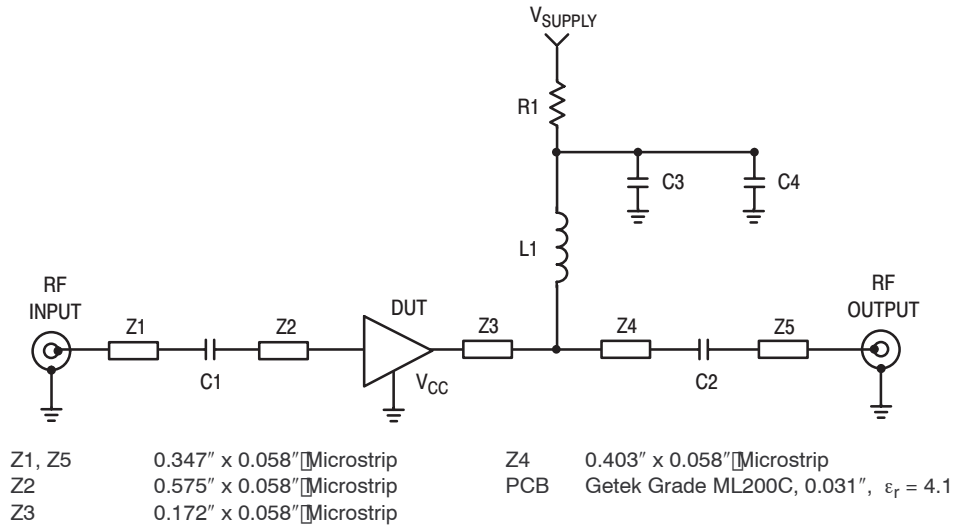

Figure 14. 50 Ohm Test Circuit Schematic

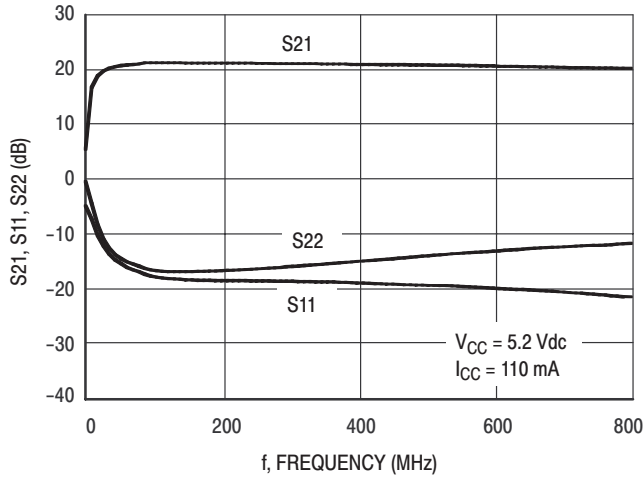
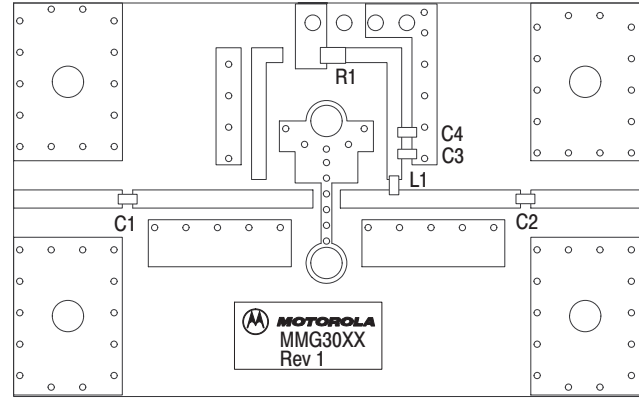

Figure 15. S21, S11 and S22 versus Frequency



Freescle has begun the transition of marking Printed Circuit Boards (PCBs) with the Freescle Semiconductor signature/logo. PCBs may have either Motorola or Freescle markings during the transition period. These changes will have no impact on form, fit or function of the current product.

Figure 16. 50 Ohm Test Circuit Component Layout

Table 8. 50 Ohm Test Circuit Component Designations and Values

Part	Description	Part Number	Manufacturer
C1, C2	0.01 μ F Chip Capacitors	0603A103JAT2A	AVX
C3	0.1 μ F Chip Capacitor	0603A102JAT2A	AVX
C4	1 μ F Chip Capacitor	0603A105JAT2A	AVX
L1	470 nH Chip Inductor	BK2125HM471	Taiyo Yuden
R1	7.5 Ω Chip Resistor	RK73B2AT7R5J	KOA Speer

Table 9. Supply Voltage versus R1 Values

Supply Voltage	6	7	8	9	10	11	12	V
R1 Value	7.3	16	25	35	44	53	62	Ω

Note: To provide $V_{CC} = 5.2$ Vdc and $I_{CC} = 110$ mA at the device.

50 OHM APPLICATION CIRCUIT: 800–3400 MHz

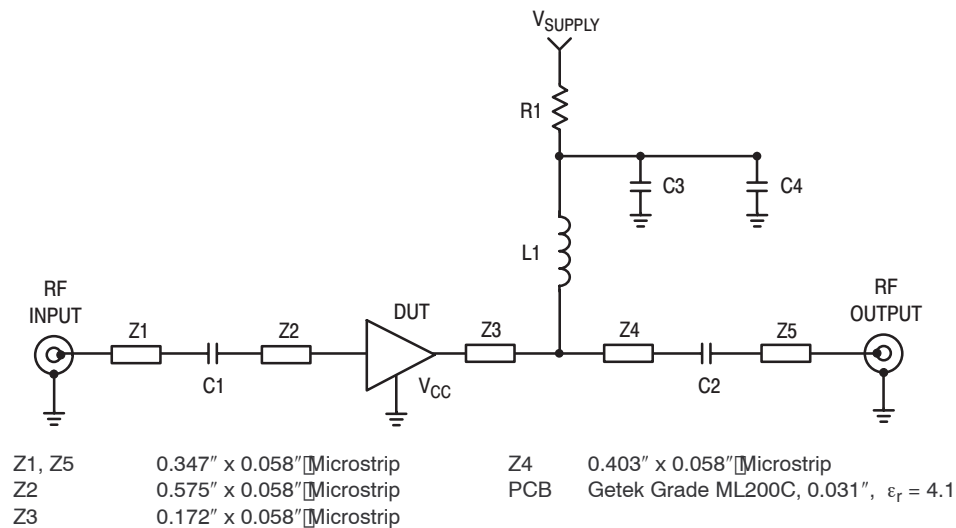

Figure 17. 50 Ohm Test Circuit Schematic

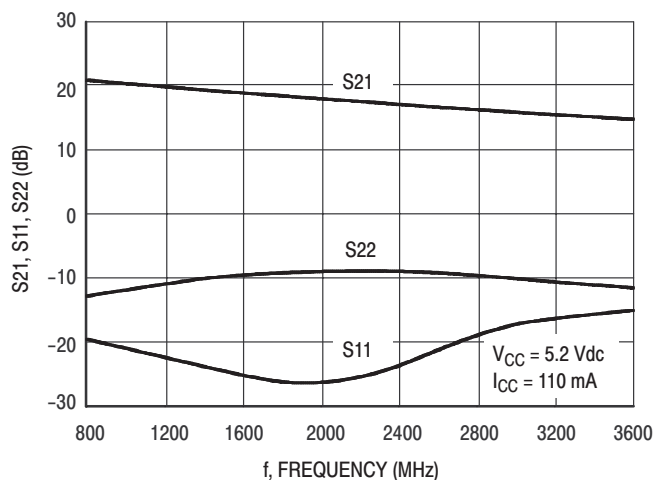
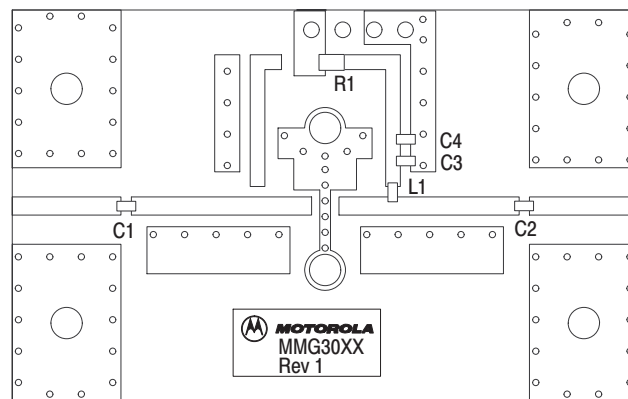

Figure 18. S21, S11 and S22 versus Frequency



Freescle has begun the transition of marking Printed Circuit Boards (PCBs) with the Freescle Semiconductor signature/logo. PCBs may have either Motorola or Freescle markings during the transition period. These changes will have no impact on form, fit or function of the current product.

Figure 19. 50 Ohm Test Circuit Component Layout

Table 10. 50 Ohm Test Circuit Component Designations and Values

Part	Description	Part Number	Manufacturer
C1, C2	150 pF Chip Capacitors	0603A151JAT2A	AVX
C3	0.1 μ F Chip Capacitor	0603A102JAT2A	AVX
C4	1 μ F Chip Capacitor	0603A105JAT2A	AVX
L1	56 nH Chip Inductor	HK160856NJ-T	Taiyo Yuden
R1	7.5 Ω Chip Resistor	RK73B2AT7R5J	KOA Speer

50 OHM APPLICATION CIRCUIT: 3.4–3.6 GHz

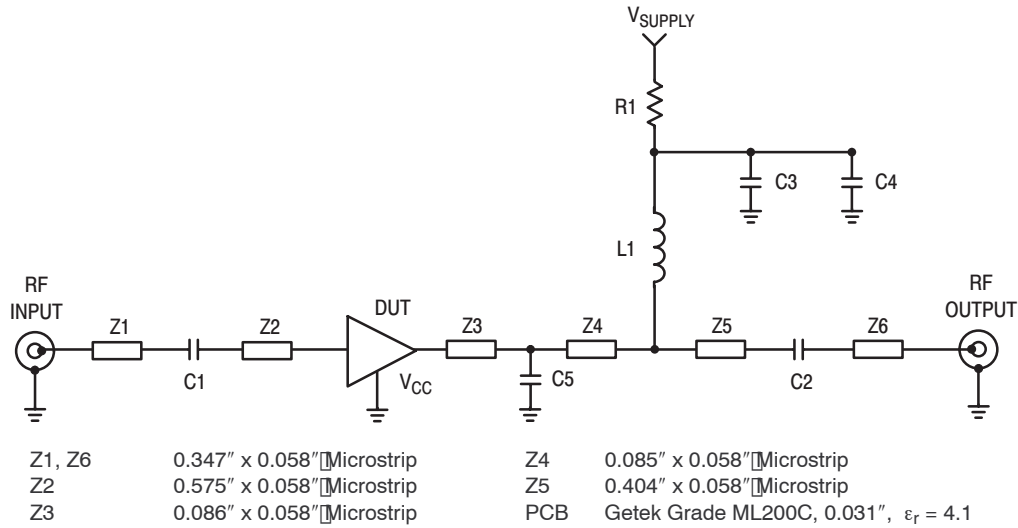

Figure 20. 50 Ohm Test Circuit Schematic

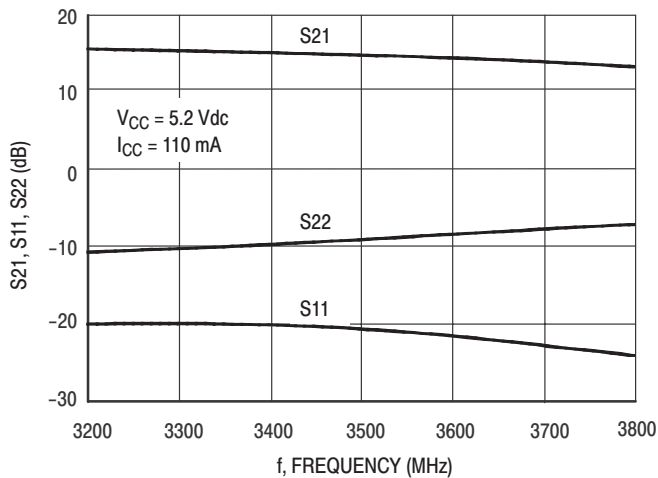
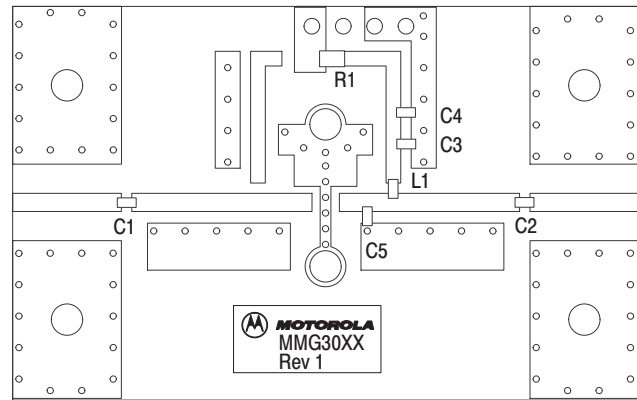

Figure 21. S21, S11 and S22 versus Frequency



Freescle has begun the transition of marking Printed Circuit Boards (PCBs) with the Freescle Semiconductor signature/logo. PCBs may have either Motorola or Freescle markings during the transition period. These changes will have no impact on form, fit or function of the current product.

Figure 22. 50 Ohm Test Circuit Component Layout

Table 11. 50 Ohm Test Circuit Component Designations and Values

Part	Description	Part Number	Manufacturer
C1, C2	150 pF Chip Capacitors	0603A151JAT2A	AVX
C3	0.1 μF Chip Capacitor	0603A102JAT2A	AVX
C4	1 μF Chip Capacitor	0603A105JAT2A	AVX
C5 (1)	0.1 pF Chip Capacitor for 3400–3600 MHz	06035J0R1BBT	AVX
L1	39 nH Chip Inductor	HK160839NJ-T	Taiyo Yuden
R1	7.5 Ω Chip Resistor	RK73B2AT7R5J	KOA Speer

1. Tuning capacitor: Capacitor value and location on the transmission line are varied for different frequencies.

50 OHM TYPICAL CHARACTERISTICS

Table 12. Class A Common Emitter S-Parameters at $V_{CC} = 5.2$ Vdc, $I_{CC} = 110$ mA, $T_C = 25^\circ\text{C}$

f GHz	S ₁₁		S ₂₁		S ₁₂		S ₂₂	
	S ₁₁	∠ φ	S ₂₁	∠ φ	S ₁₂	∠ φ	S ₂₂	∠ φ
0.1	0.05966	176.181	10.25158	174.805	0.07235	-0.722	0.04946	-167.612
0.15	0.07228	-178.627	9.96687	171.111	0.07071	-1.821	0.0953	-129.396
0.2	0.09041	151.476	10.46556	167.719	0.07464	-3.053	0.05913	-124.668
0.25	0.0909	149.96	10.36837	164.949	0.07424	-3.553	0.08015	-125.378
0.3	0.08882	145.472	10.30366	162.017	0.07406	-4.277	0.09694	-122.814
0.35	0.08508	140.833	10.2505	158.995	0.07407	-4.934	0.11062	-121.876
0.4	0.08377	136.078	10.17971	156.158	0.07405	-5.7	0.12723	-122.007
0.45	0.08191	131.492	10.10383	153.293	0.07365	-6.307	0.14156	-122.555
0.5	0.07982	125.857	10.02536	150.437	0.07358	-7.037	0.15558	-123.436
0.55	0.07776	120.816	9.94165	147.642	0.07346	-7.676	0.1685	-124.8
0.6	0.0773	115.435	9.85596	144.898	0.07336	-8.2	0.18177	-126.796
0.65	0.07677	110.371	9.76098	142.109	0.07321	-8.911	0.19472	-128.506
0.7	0.07664	104.874	9.6623	139.374	0.07301	-9.464	0.20662	-130.47
0.75	0.07628	100.112	9.56168	136.692	0.0729	-10.069	0.21833	-132.663
0.8	0.07619	95.73	9.45426	134.024	0.07275	-10.618	0.22977	-134.835
0.85	0.07601	91.72	9.34921	131.391	0.07273	-11.184	0.24125	-137.084
0.9	0.07567	87.313	9.23967	128.792	0.07257	-11.821	0.25232	-139.685
0.95	0.07642	83.036	9.13144	126.149	0.07238	-12.312	0.26303	-142.257
1	0.07619	80.021	9.01205	123.659	0.07228	-12.88	0.27394	-144.736
1.05	0.07666	76.201	8.90327	121.137	0.07218	-13.474	0.28332	-147.346
1.1	0.07678	73.008	8.78013	118.657	0.07202	-13.93	0.29417	-150.042
1.15	0.07673	70.68	8.66342	116.191	0.0719	-14.519	0.30394	-152.767
1.2	0.07674	68.773	8.53991	113.779	0.07178	-15.062	0.31393	-155.358
1.25	0.07628	66.216	8.42251	111.392	0.07176	-15.551	0.32286	-157.992
1.3	0.07618	64.635	8.30514	109.034	0.07164	-16.115	0.33259	-160.483
1.35	0.07454	62.959	8.18109	106.673	0.07149	-16.539	0.34127	-162.981
1.4	0.07373	60.65	8.06498	104.367	0.07152	-17.114	0.34972	-165.377
1.45	0.0724	59.062	7.94403	102.073	0.07137	-17.565	0.35931	-167.823
1.5	0.06466	48.656	7.85198	99.72	0.0715	-18.187	0.35762	-170.82
1.55	0.0646	44.563	7.73641	97.503	0.07167	-18.755	0.36484	-172.845
1.6	0.06495	39.856	7.63068	95.372	0.07161	-19.217	0.37158	-174.751
1.65	0.0657	35.953	7.52257	93.247	0.07165	-19.614	0.37821	-176.697
1.7	0.06599	31.949	7.43591	91.089	0.07171	-20.239	0.38558	-178.85
1.75	0.0666	28.693	7.31976	88.981	0.07168	-20.731	0.39036	179.588
1.8	0.06649	25.448	7.22121	86.872	0.07176	-21.241	0.39732	177.775
1.85	0.06637	22.687	7.11782	84.83	0.07181	-21.685	0.40211	175.992
1.9	0.06563	19.369	7.01794	82.771	0.07188	-22.233	0.40749	174.294
1.95	0.06514	15.516	6.91688	80.824	0.07197	-22.678	0.41306	172.684
2	0.0641	13.294	6.82126	78.739	0.07217	-23.218	0.41825	170.97
2.05	0.06323	9.843	6.72865	76.797	0.07214	-23.632	0.42367	169.372
2.1	0.06288	6.976	6.63794	74.849	0.07234	-24.15	0.42905	167.644
2.15	0.06195	4.218	6.55483	72.888	0.07244	-24.689	0.43442	166.014
2.2	0.06084	2.075	6.46275	70.939	0.07265	-25.273	0.43857	164.274
2.25	0.05942	-0.3	6.37821	69.013	0.07275	-25.755	0.44419	162.598
2.3	0.05808	-2.187	6.29055	67.098	0.07295	-26.316	0.44756	160.879
2.35	0.05526	-4.038	6.20851	65.179	0.07318	-26.813	0.45231	159.11

MMG3002NT1

Table 12. Class A Common Emitter S-Parameters at $V_{CC} = 5.2$ Vdc, $I_{CC} = 110$ mA, $T_C = 25^\circ\text{C}$ (continued)

f GHz	S ₁₁		S ₂₁		S ₁₂		S ₂₂	
	S ₁₁	∠ φ	S ₂₁	∠ φ	S ₁₂	∠ φ	S ₂₂	∠ φ
2.4	0.05338	-6.096	6.12256	63.315	0.07337	-27.387	0.45571	157.425
2.45	0.05054	-7.643	6.04461	61.45	0.07359	-27.903	0.46063	155.679
2.5	0.04768	-10.036	5.96594	59.564	0.07386	-28.462	0.46419	153.884
2.55	0.04494	-12.811	5.88833	57.733	0.07416	-29.19	0.4681	152.005
2.6	0.04239	-14.731	5.81782	55.868	0.07435	-29.754	0.47249	150.142
2.65	0.0393	-16.676	5.74121	53.98	0.07445	-30.312	0.47601	148.126
2.7	0.03707	-20.889	5.66538	52.04	0.0748	-31.053	0.47991	146.214
2.75	0.0346	-21.7	5.59155	50.247	0.07499	-31.654	0.48371	144.147
2.8	0.03163	-24.056	5.51967	48.401	0.07519	-32.344	0.48777	142.183
2.85	0.02869	-26.756	5.44631	46.54	0.0754	-33.048	0.49144	140.072
2.9	0.02667	-28.324	5.37422	44.74	0.07563	-33.749	0.4961	138.081
2.95	0.02324	-29.457	5.30336	42.914	0.07577	-34.431	0.50017	136.001
3	0.02069	-34.403	5.23613	41.138	0.07596	-35.209	0.5054	133.872
3.05	0.01861	-37.625	5.16698	39.322	0.07624	-35.917	0.50901	131.91
3.1	0.01563	-41.101	5.09908	37.495	0.07648	-36.648	0.51431	129.855
3.15	0.01407	-49.967	5.03148	35.696	0.0766	-37.389	0.51844	127.844
3.2	0.01296	-54.052	4.96452	33.935	0.07684	-38.12	0.52333	125.818
3.25	0.01129	-59.44	4.89769	32.159	0.07708	-38.894	0.52814	123.86
3.3	0.01031	-67.904	4.83271	30.407	0.07721	-39.663	0.53368	121.891
3.35	0.00977	-71.657	4.76883	28.702	0.07742	-40.479	0.53765	120.096
3.4	0.00821	-77.779	4.707	26.984	0.07764	-41.116	0.54299	118.206
3.45	0.0076	-90.054	4.64886	25.288	0.07774	-41.964	0.54702	116.357
3.5	0.0074	-97.151	4.59041	23.575	0.07797	-42.707	0.55121	114.75
3.55	0.00666	-114.876	4.5319	21.885	0.07819	-43.538	0.55593	113.11
3.6	0.00749	-127.171	4.47455	20.231	0.07843	-44.293	0.55935	111.522

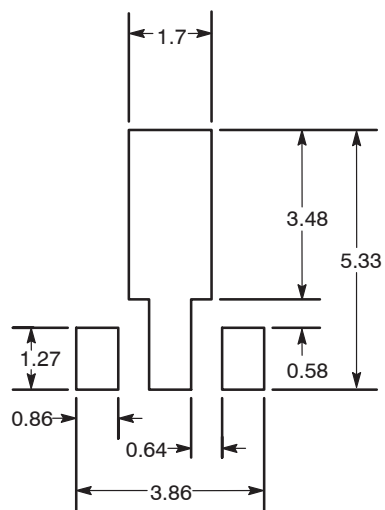

Recommended Solder Stencil

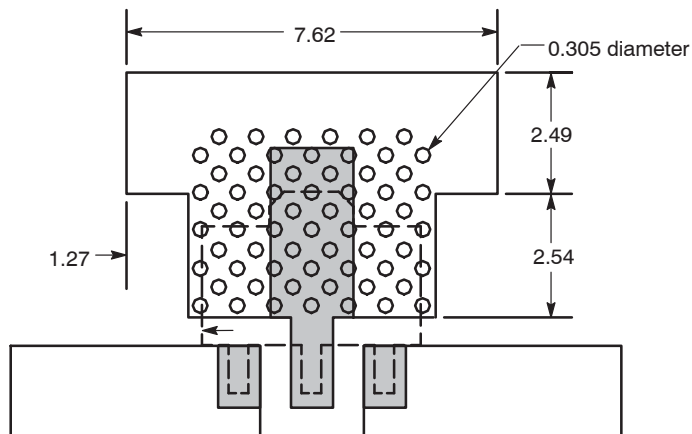

NOTES:

1. THERMAL AND RF GROUNDING CONSIDERATIONS SHOULD BE USED IN PCB LAYOUT DESIGN.
2. DEPENDING ON PCB DESIGN RULES, AS MANY VIAS AS POSSIBLE SHOULD BE PLACED ON THE LANDING PATTERN.
3. IF VIAS CANNOT BE PLACED ON THE LANDING PATTERN, THEN AS MANY VIAS AS POSSIBLE SHOULD BE PLACED AS CLOSE TO THE LANDING PATTERN AS POSSIBLE FOR OPTIMAL THERMAL AND RF PERFORMANCE.
4. RECOMMENDED VIA PATTERN SHOWN HAS 0.381 x 0.762 MM PITCH.

Figure 23. Recommended Mounting Configuration



NOTES



NOTES



NOTES

PACKAGE DIMENSIONS

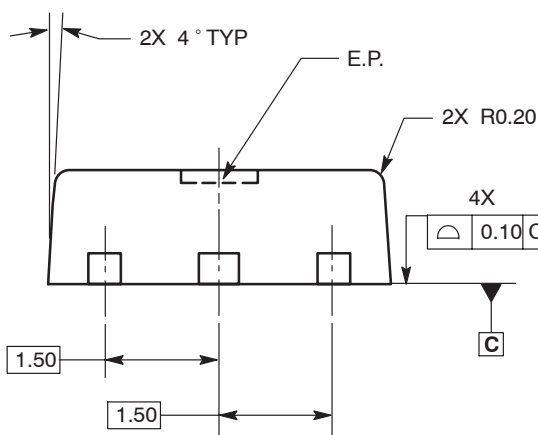
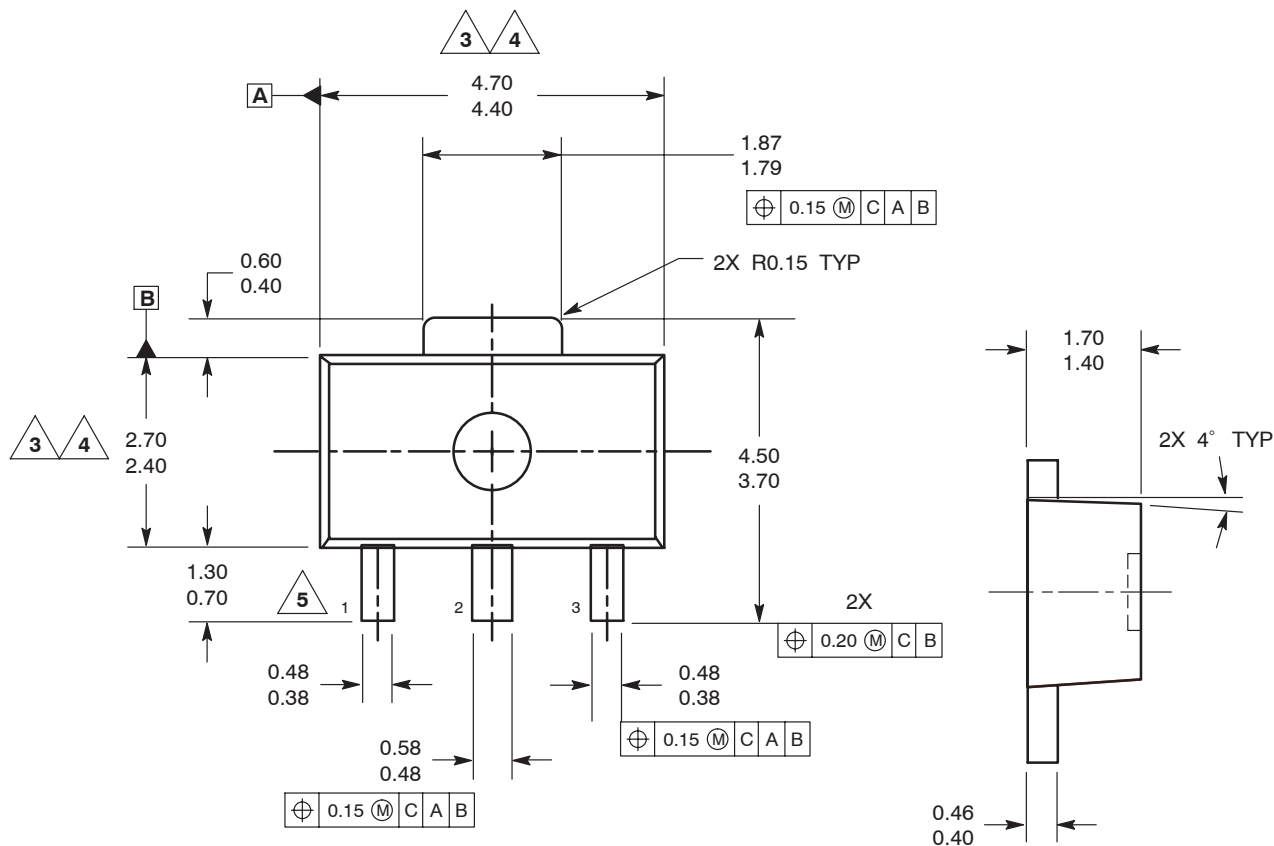

- NOTES:
1. DIMENSIONING AND TOLERANCING PER ASME Y14.5M, 1994.
 2. ALL DIMENSIONS ARE IN MILLIMETERS.
 3. DIMENSION DOES NOT INCLUDE MOLD FLASH, PROTRUSIONS OR GATE BURRS. MOLD FLASH, PROTRUSIONS OR GATE BURRS SHALL NOT EXCEED 0.5MM PER END. DIMENSION DOES NOT INCLUDE INTERLEAD FLASH OR PROTRUSION. INTERLEAD FLASH OR PROTRUSION SHALL NOT EXCEED 0.5MM PER SIDE.
 4. DIMENSIONS ARE DETERMINED AT THE OUTMOST EXTREMES OF THE PLASTIC BODY EXCLUSIVE OF MOLD FLASH, TIE BAR BURRS, GATE BURRS AND INTERLEAD FLASH, BUT INCLUDING ANY MISMATCH BETWEEN THE TOP AND BOTTOM OF THE PLASTIC BODY.
 5. TERMINAL NUMBERS ARE SHOWN FOR REFERENCE ONLY.

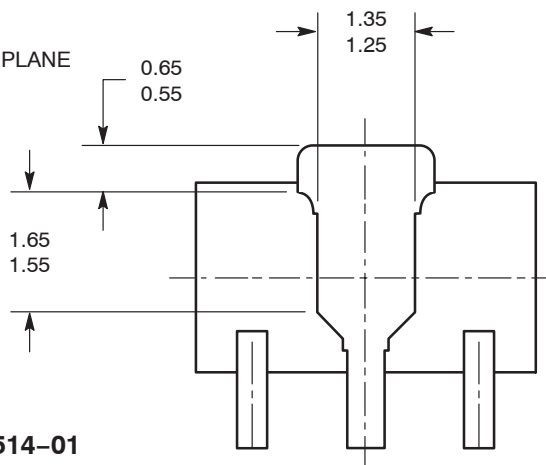

STYLE 1:
 PIN 1. RF INPUT
 2. GROUND
 3. RF OUTPUT

CASE 1514-01
 ISSUE A
 SOT-89
 PLASTIC

BOTTOM VIEW

MMG3002NT1

How to Reach Us:

Home Page:

www.freescale.com

E-mail:

support@freescale.com

USA/Europe or Locations Not Listed:

Freescale Semiconductor
Technical Information Center, CH370
1300 N. Alma School Road
Chandler, Arizona 85224
+1-800-521-6274 or +1-480-768-2130
support@freescale.com

Europe, Middle East, and Africa:

Freescale Halbleiter Deutschland GmbH
Technical Information Center
Schatzbogen 7
81829 Muenchen, Germany
+44 1296 380 456 (English)
+46 8 52200080 (English)
+49 89 92103 559 (German)
+33 1 69 35 48 48 (French)
support@freescale.com

Japan:

Freescale Semiconductor Japan Ltd.
Headquarters
ARCO Tower 15F
1-8-1, Shimo-Meguro, Meguro-ku,
Tokyo 153-0064
Japan
0120 191014 or +81 3 5437 9125
support.japan@freescale.com

Asia/Pacific:

Freescale Semiconductor Hong Kong Ltd.
Technical Information Center
2 Dai King Street
Tai Po Industrial Estate
Tai Po, N.T., Hong Kong
+800 2666 8080
support.asia@freescale.com

For Literature Requests Only:

Freescale Semiconductor Literature Distribution Center
P.O. Box 5405
Denver, Colorado 80217
1-800-441-2447 or 303-675-2140
Fax: 303-675-2150
LDCForFreescaleSemiconductor@hibbertgroup.com

Information in this document is provided solely to enable system and software implementers to use Freescale Semiconductor products. There are no express or implied copyright licenses granted hereunder to design or fabricate any integrated circuits or integrated circuits based on the information in this document.

Freescale Semiconductor reserves the right to make changes without further notice to any products herein. Freescale Semiconductor makes no warranty, representation or guarantee regarding the suitability of its products for any particular purpose, nor does Freescale Semiconductor assume any liability arising out of the application or use of any product or circuit, and specifically disclaims any and all liability, including without limitation consequential or incidental damages. "Typical" parameters that may be provided in Freescale Semiconductor data sheets and/or specifications can and do vary in different applications and actual performance may vary over time. All operating parameters, including "Typicals", must be validated for each customer application by customer's technical experts. Freescale Semiconductor does not convey any license under its patent rights nor the rights of others. Freescale Semiconductor products are not designed, intended, or authorized for use as components in systems intended for surgical implant into the body, or other applications intended to support or sustain life, or for any other application in which the failure of the Freescale Semiconductor product could create a situation where personal injury or death may occur. Should Buyer purchase or use Freescale Semiconductor products for any such unintended or unauthorized application, Buyer shall indemnify and hold Freescale Semiconductor and its officers, employees, subsidiaries, affiliates, and distributors harmless against all claims, costs, damages, and expenses, and reasonable attorney fees arising out of, directly or indirectly, any claim of personal injury or death associated with such unintended or unauthorized use, even if such claim alleges that Freescale Semiconductor was negligent regarding the design or manufacture of the part.

Freescale™ and the Freescale logo are trademarks of Freescale Semiconductor, Inc. All other product or service names are the property of their respective owners.
© Freescale Semiconductor, Inc. 2005. All rights reserved.

